



TREKHAKEN • ATTELAGES • ANHÄNGERVORRICHTUNGEN • TOWBARS • ENHANCES • ANHÆNGERTRÆK

Montagehandleiding | instructions de montage | Einbauanleitung | Mounting instruction
Instrucciones de montaje | monteringsvejledning



Mazda CX-30

07/'19 -

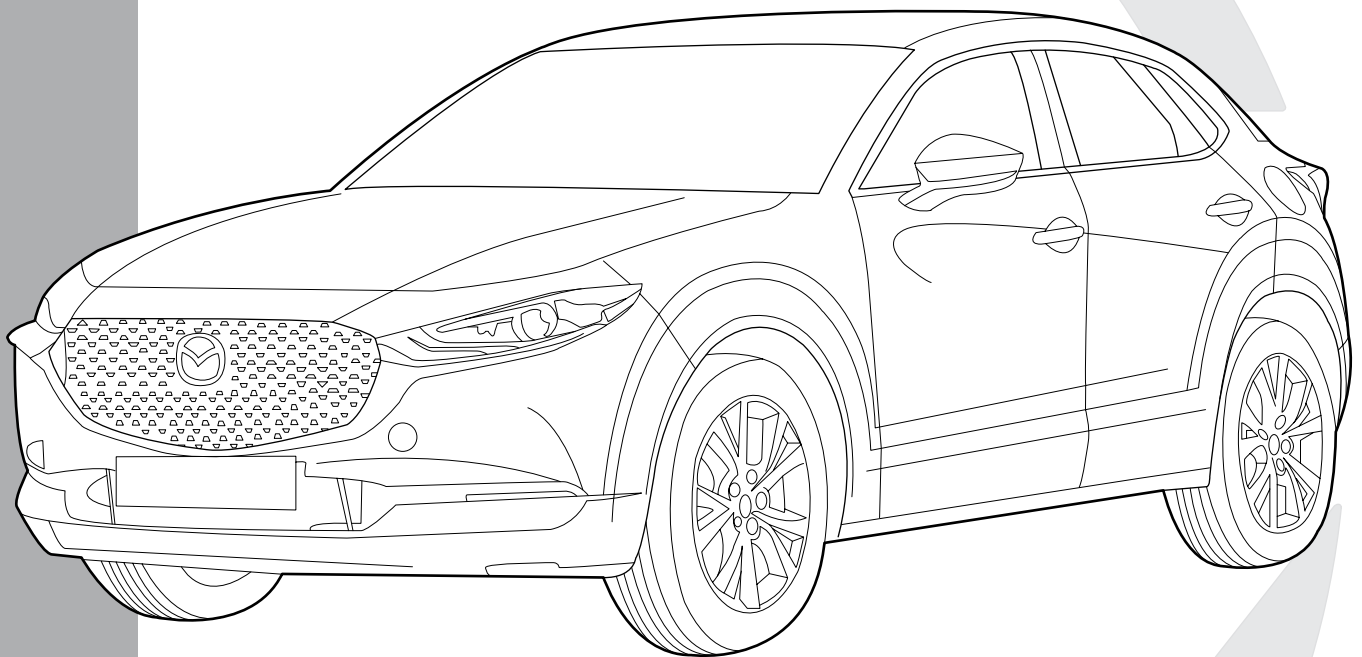

Montage

- Voor de montage moet de trekhaak eerst op het voertuig gepresenteerd worden.

De belasting van een aanhangwagen en van een accessoire dat op de koppelingskogel wordt voorzien, zijn anders van aard. Voor beiden kunnen verschillende limieten van toepassing zijn. Hiervoor verwijzen we naar het instructieboekje van de wagen of naar uw concessiehouder.

Montage

- Présenter l'attelage sous le véhicule avant d'effectuer le montage.

La charge d'une remorque ou d'un accessoire prévue sur la boule d'attelage, est de nature diverse. Pour ces deux éléments, il peut y avoir des limites d'utilisation. Nous vous recommandons de vous référer à votre livret d'instructions ou de vous renseigner chez votre concessionnaire.

Fitting

- Present the towbar under the car first to check if all points are right.

The load of a trailer and of an accessory fitted on the towing ball are of a different nature. Different limits may apply to both. For this matter, we refer to the instruction manual of the vehicle or we advise you to contact your concessionaire.

Montage

- Erst die Anhängerkupplung und das Fahrzeug kontrollieren, danach montieren.

Die Belastung eines Anhängers und eines Zubehörs, die man auf einer Kupplungskugel voraussieht, ist wesentlich anders. Für beide gilt, dass diese unterschiedlich begrenzt sein können. Deswegen möchten wir verweisen auf die Bedienungsanleitung des Fahrzeugs oder auf Ihren Vertragshändler.

Montaje

- Presentar el enganche debajo del vehículo antes de realizar el montaje.

La carga de un remolque y un accesorio montado en una bola de remolque son de una naturaleza diferente. Se pueden aplicar diferentes límites a ambos. Para este asunto, nos referimos al manual de instrucciones del vehículo o le recomendamos que contacte a su distribuidor.

Montering

- Præsenter trækstangen under bilen først for at kontrollere, om alle punkter er rigtige.

Belastningen af en trailer og af tilbehør tilkoblet anghængertrækket er forskellige. Der kan være forskellige begrænsninger på begge. I disse tilfælde henviser vi til bilens manual, eller anbefaler dig at kontakte bilforhandleren

Montaggio

- In primo luogo, presentare la struttura sotto l'automobile per verificare che tutti i punti di attacco coincidano.

La massa rimorchiabile del veicolo potrebbe essere diversa dal valore riportato sul documento del gancio di traino. Per questo motivo, vi invitiamo a consultare sempre la carta di circolazione del veicolo (Pos. O.1) o a rivolgervi alla vostro concessionario di fiducia

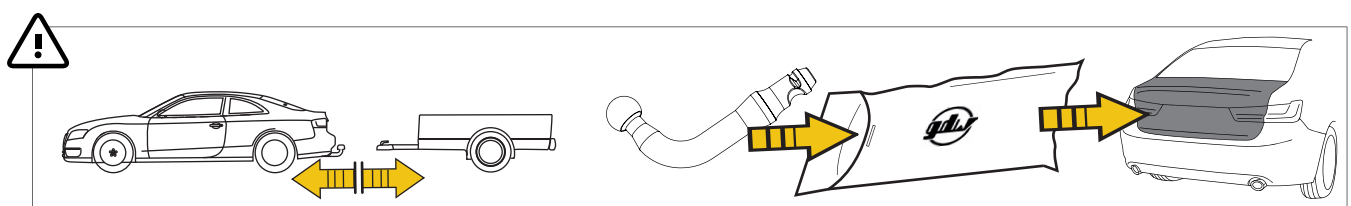
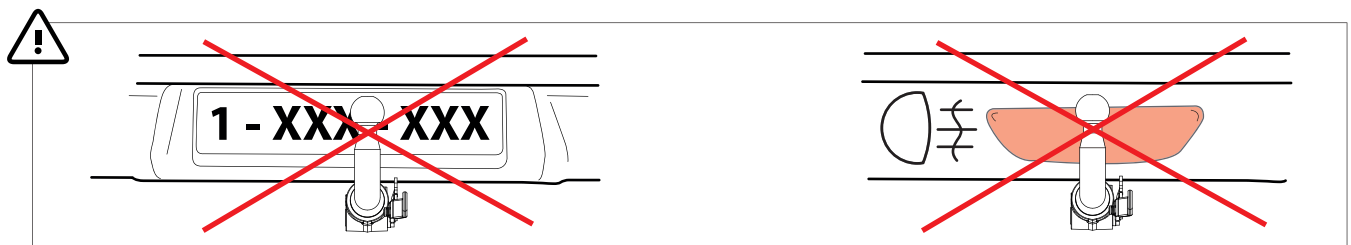
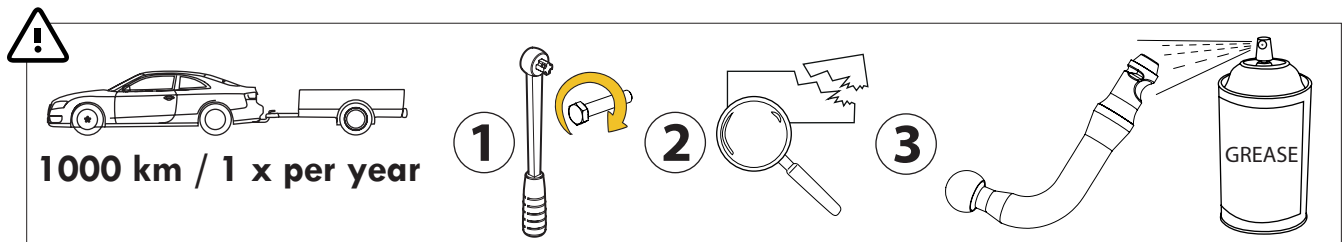
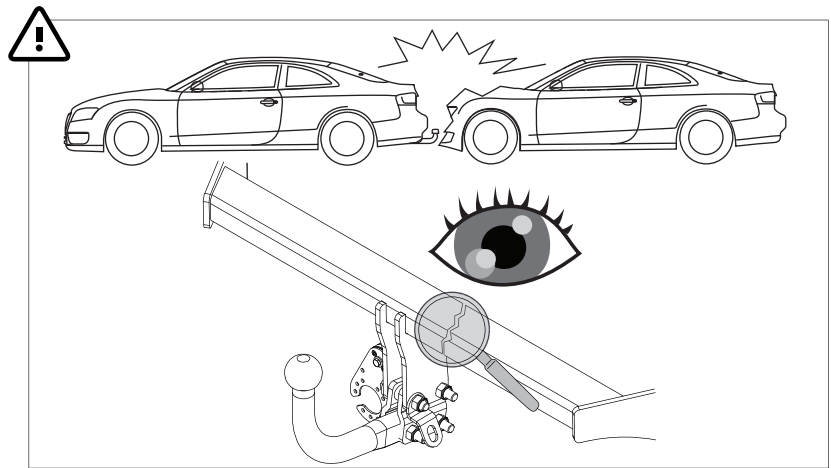
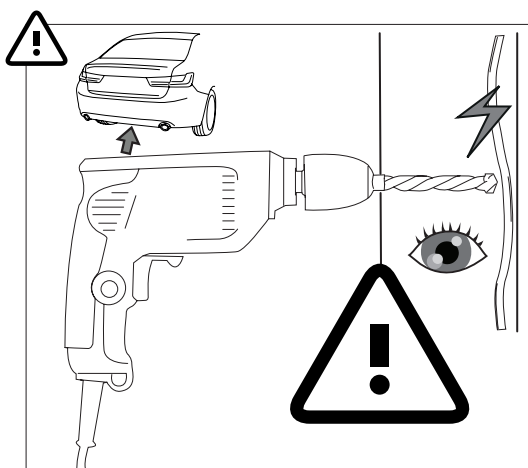
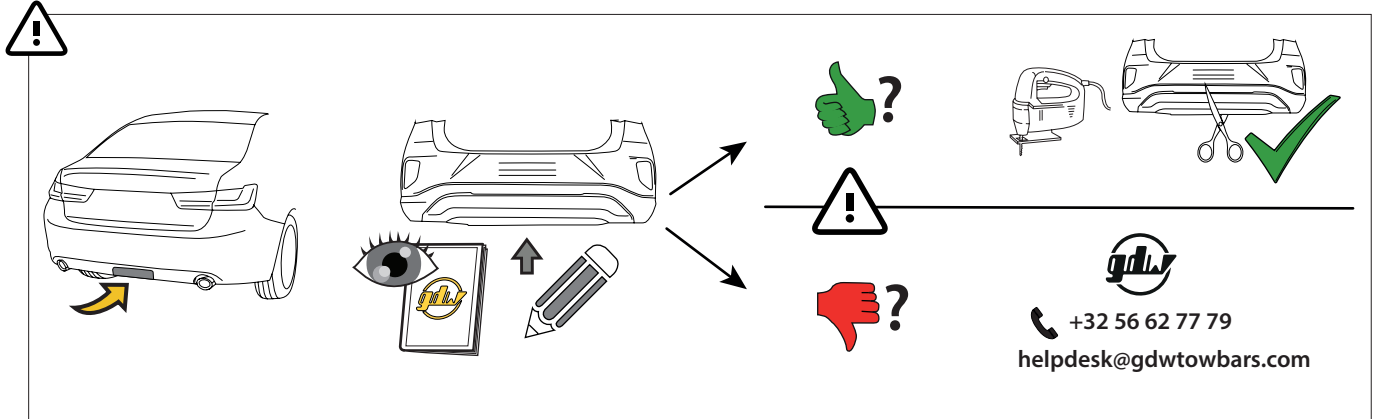
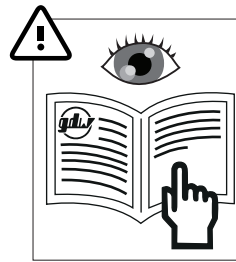
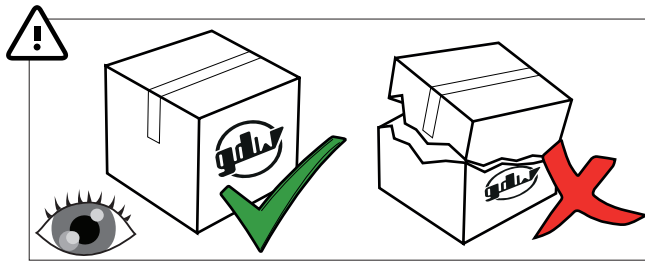



MADE BY  **D 8,85** **A50-X** **E6**

BELGIUM **S 85** **55R-011622**

REF N° **2489T60** **XXXX**









DESCRIPTION
Mazda CX-30 07/'19-







 



$$D = \frac{\text{max kg} \times \text{max kg}}{\text{max kg} + \text{max kg}} \times 0.00981 \leq 8,85 \text{ kN}$$

$$S = \begin{matrix} \leq 85 \text{ kg} & \leq 1550 \text{ kg} \end{matrix}$$

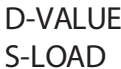
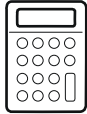
See the Certificate Of Conformity (COC) of your vehicle or contact your dealer to verify the max. trailer weight of your car!

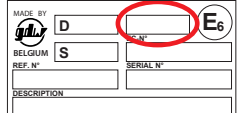
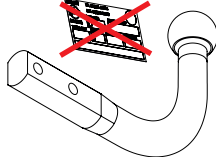
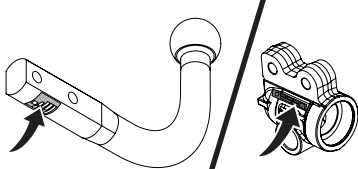

   **A50-X?**  

F? + 

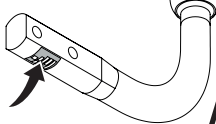
10 17 19 PH1 PH2

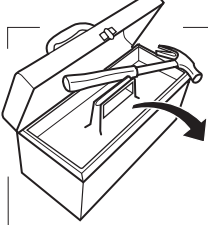
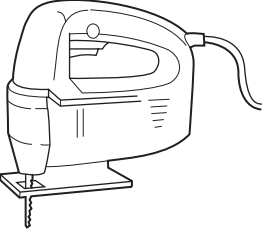

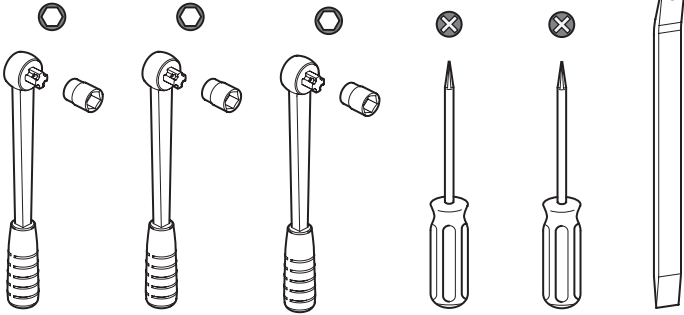

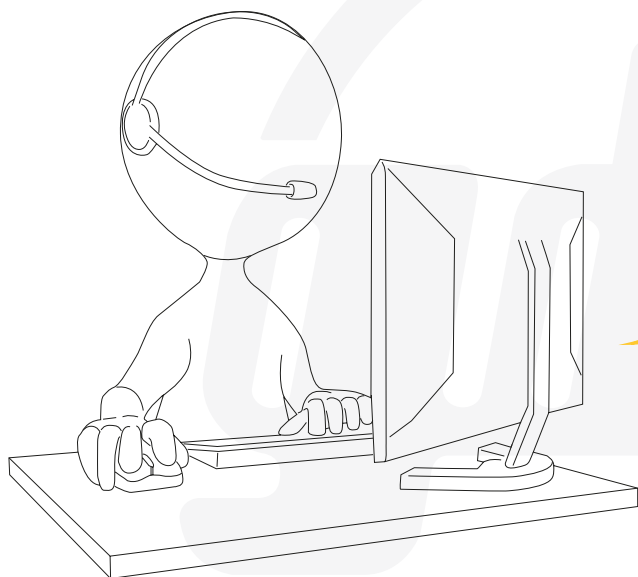





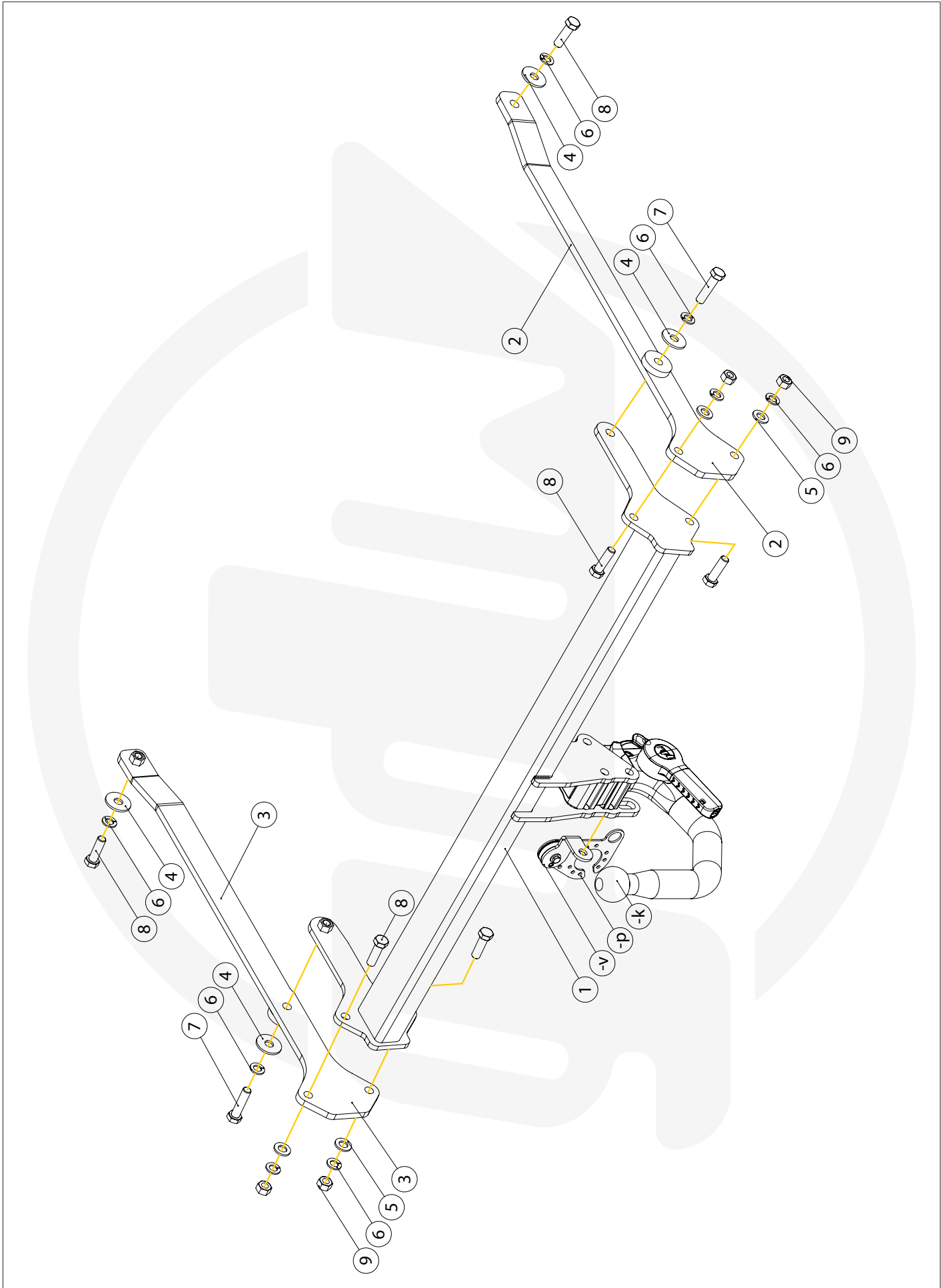

helpdesk@gdwtowbars.com

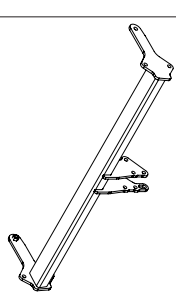
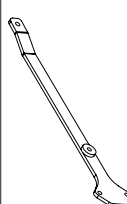
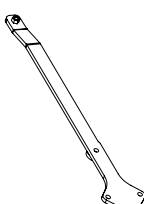





+32 56 62 77 79



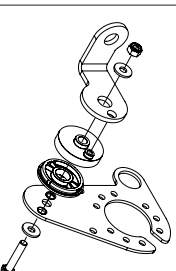



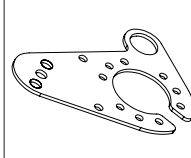

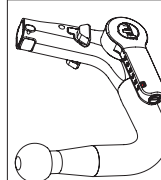

Monday	08:00 - 12:00	12:30 - 16:30
Tuesday	08:00 - 12:00	12:30 - 16:30
Wednesday	08:00 - 12:00	12:30 - 16:30
Thursday	08:00 - 12:00	12:30 - 16:30
Friday	08:00 - 12:00	12:30 - 15:30

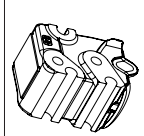

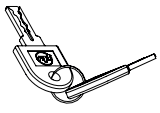

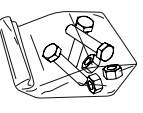
1		X1	GDW REF. 2489T60
2		X1	GDW REF. 2
3		X1	GDW REF. 3
4		X4	DIN9021-M12-ELVZ
5		X4	DIN125-A12-140HV-ELVZ
6		X8	DIN128A-M12
7		X2	DIN931-M12 X 50
8		X6	DIN933-M12 X 40
9		X4	DIN934-M12
-V		X1	GDW REF. 908.095

-P		X1	GDW REF. P39
↳		X1	DIN985-M6
↳		X2	6,2 X 15,4 X 1,6 (NYLON)
↳		X1	GDW REF. 718.16.002
↳		X1	GDW REF. 718.16.003
↳		X1	GDW REF. 908.094
↳		X1	DIN933-M6 X 30
↳		X1	GDW REF. 908.095

Geleverd met - Livré avec - Delivered with Geliefert mit - Elementos adjuntos-Leveres med		X1	GDW REF. 960.W0614
	↳ 	X1	GDW REF. 740.200
		X1	GDW REF. 912.003
	↳ 	X1	GDW REF. 740.112
	↳ 	X1	GDW REF. 740.111
		X1	GDW REF. 740.114
		X1	GDW REF. 718.15.001
		X1	GDW REF. SYST60-10
	↳ 	X3	DIN931-M12 X 110
	↳ 	X3	DIN128A-M12
	↳ 	X6	DIN125A-M12
	↳ 	X3	DIN934-M12

1

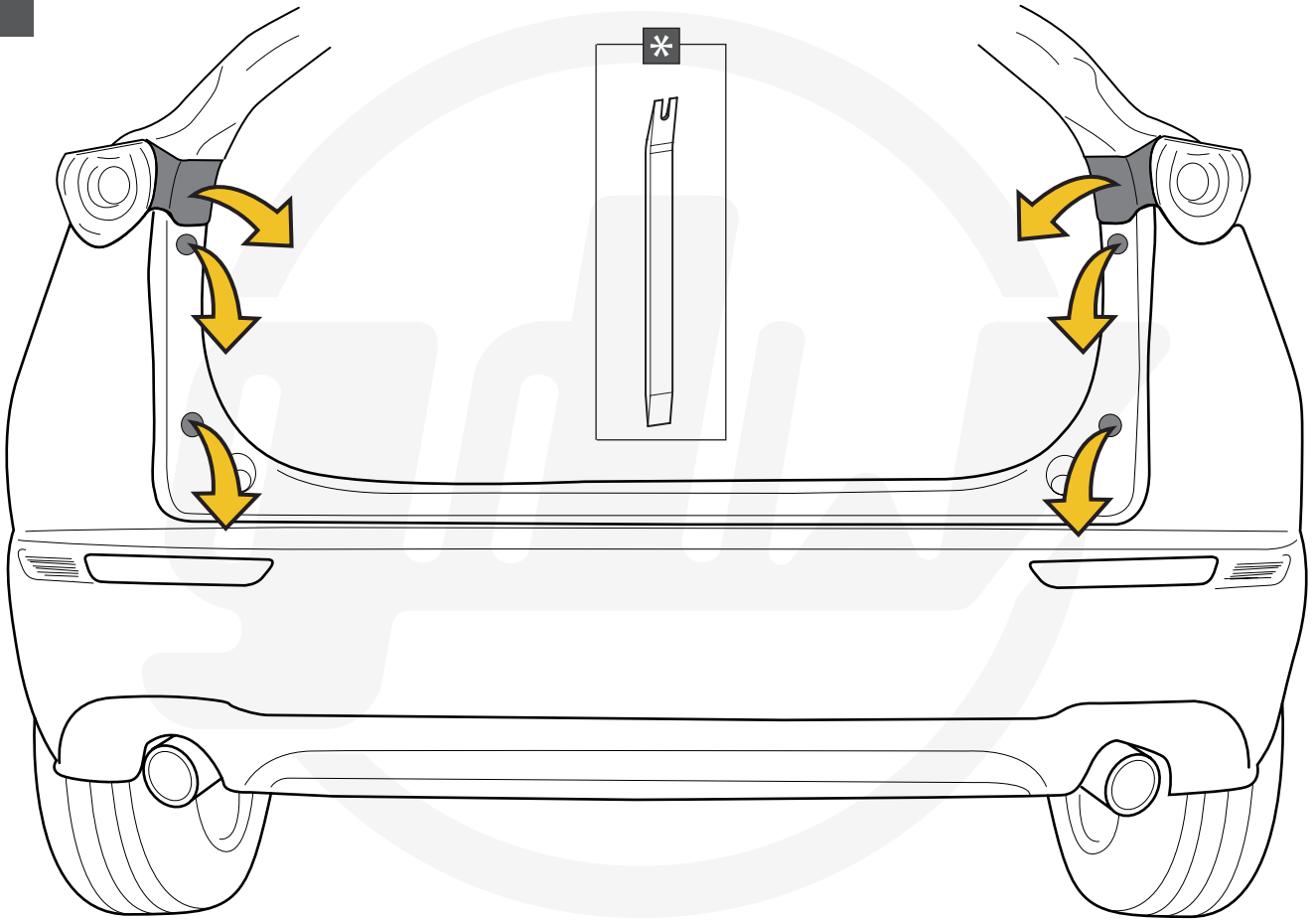

2

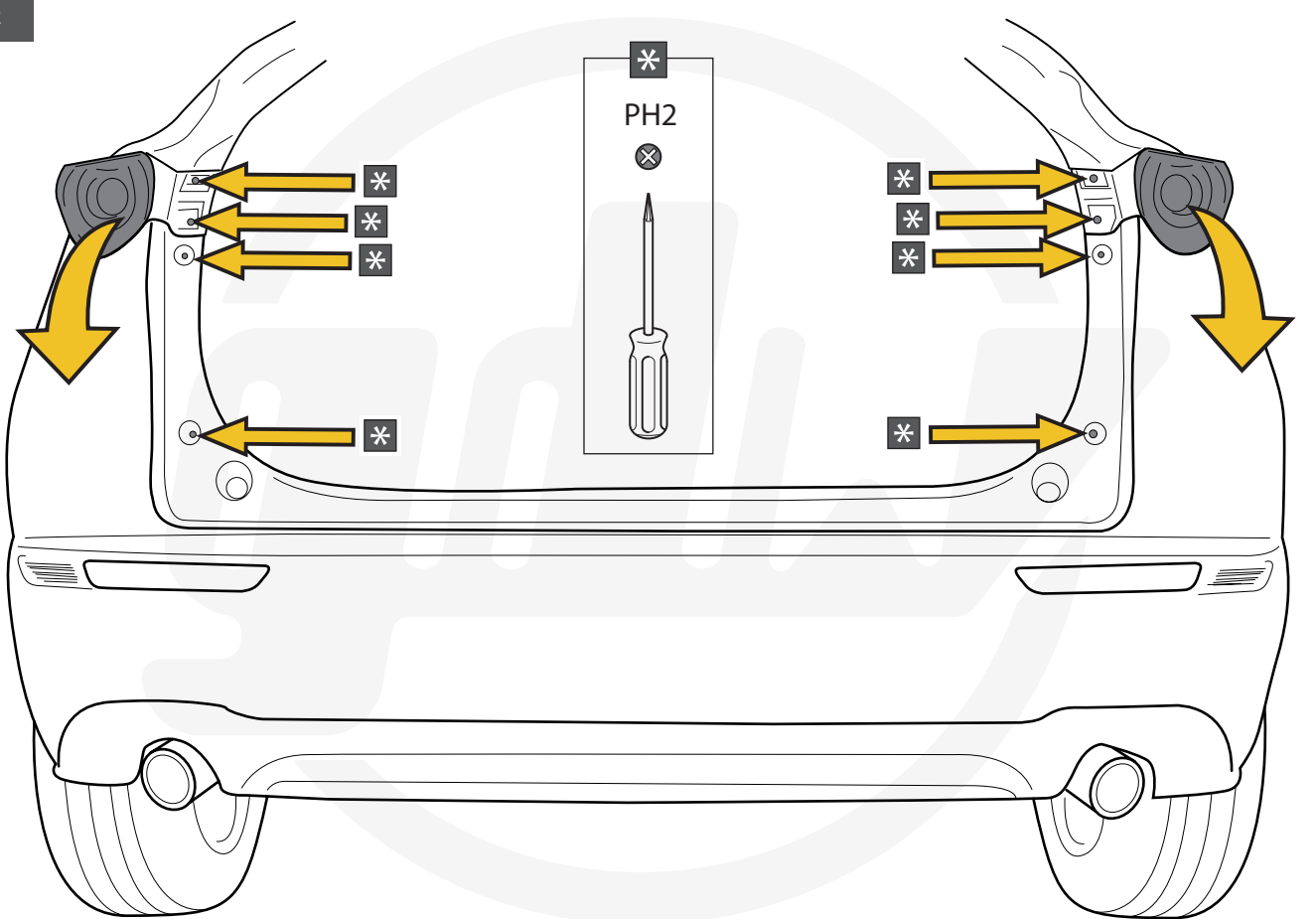

3

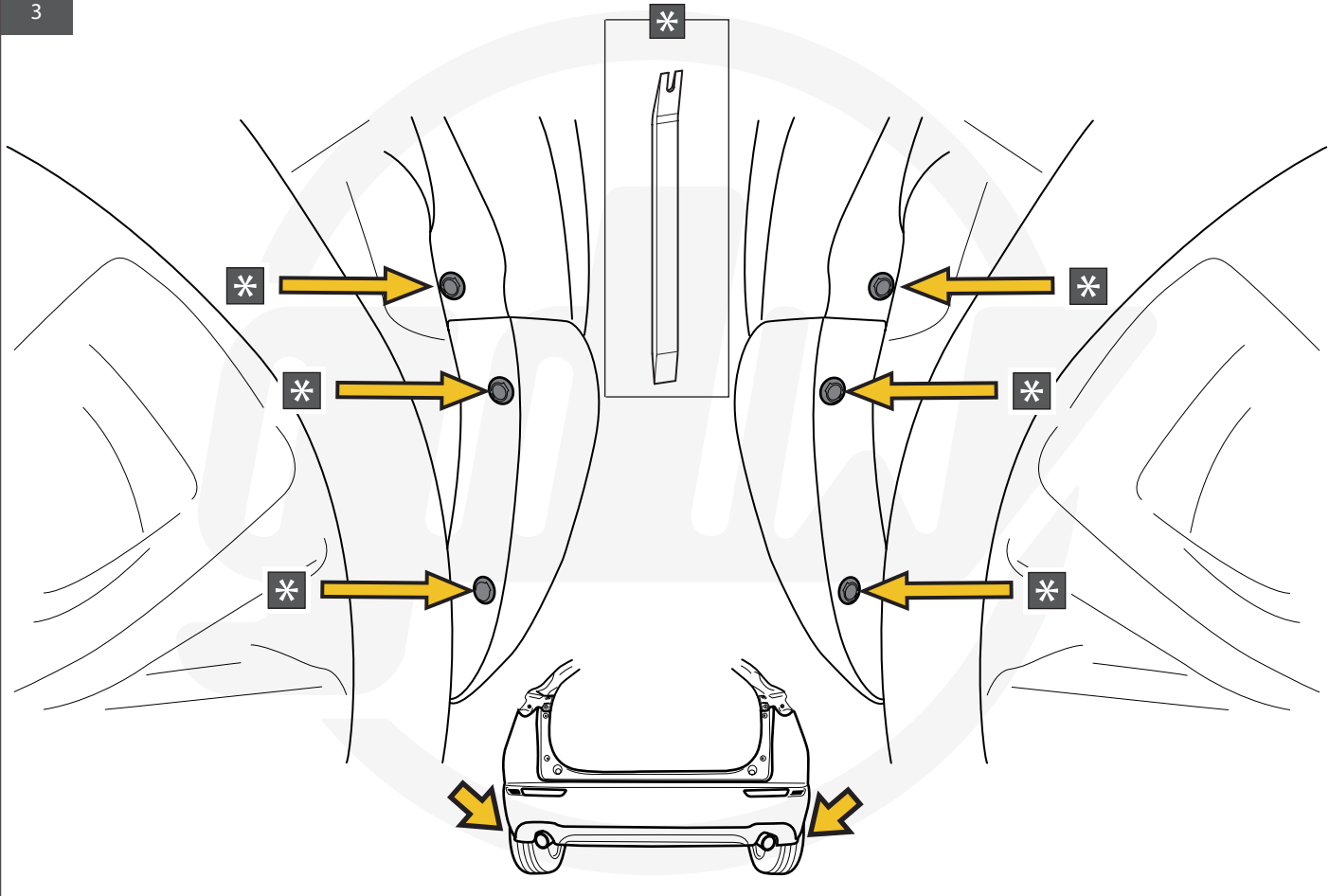

4

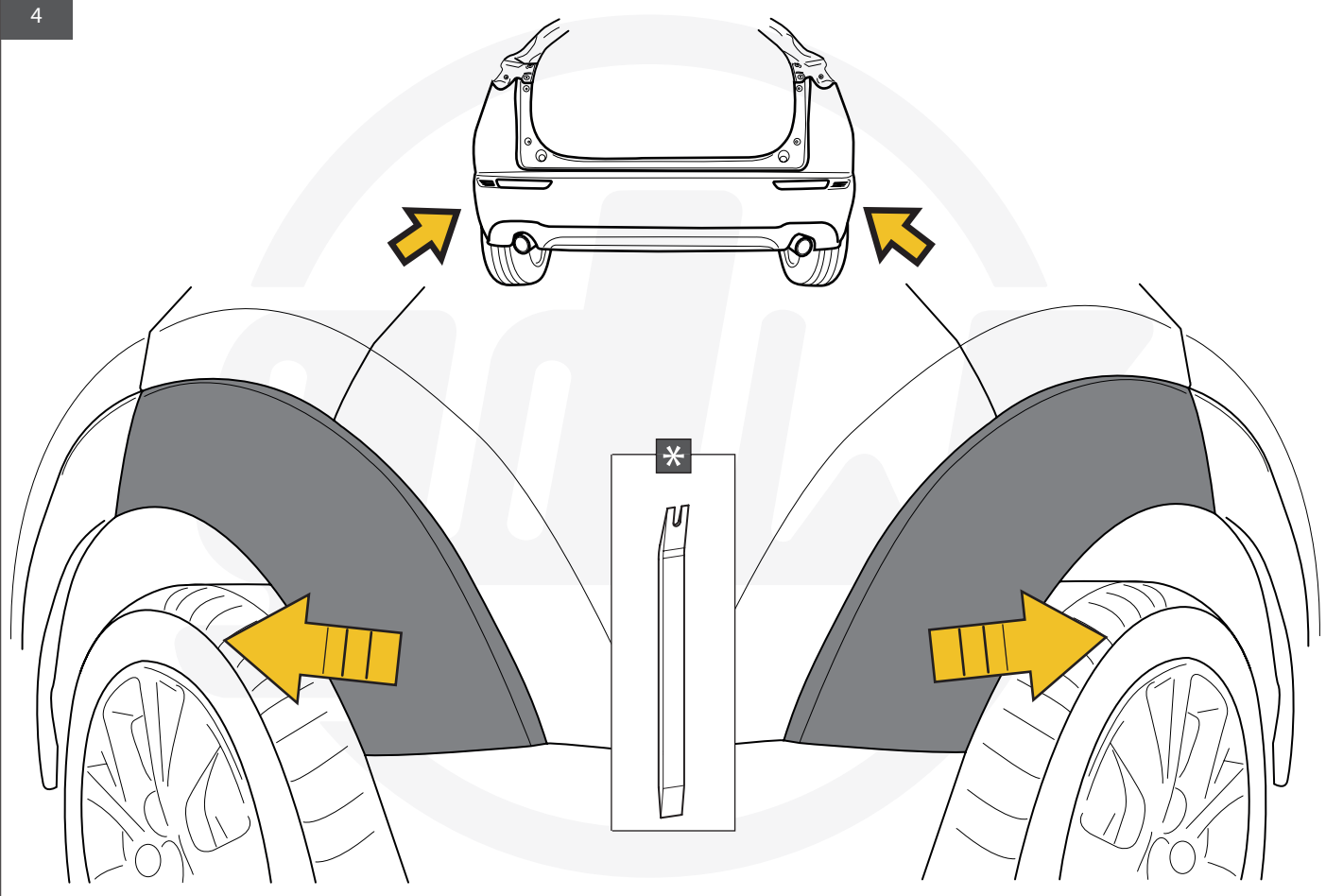

5

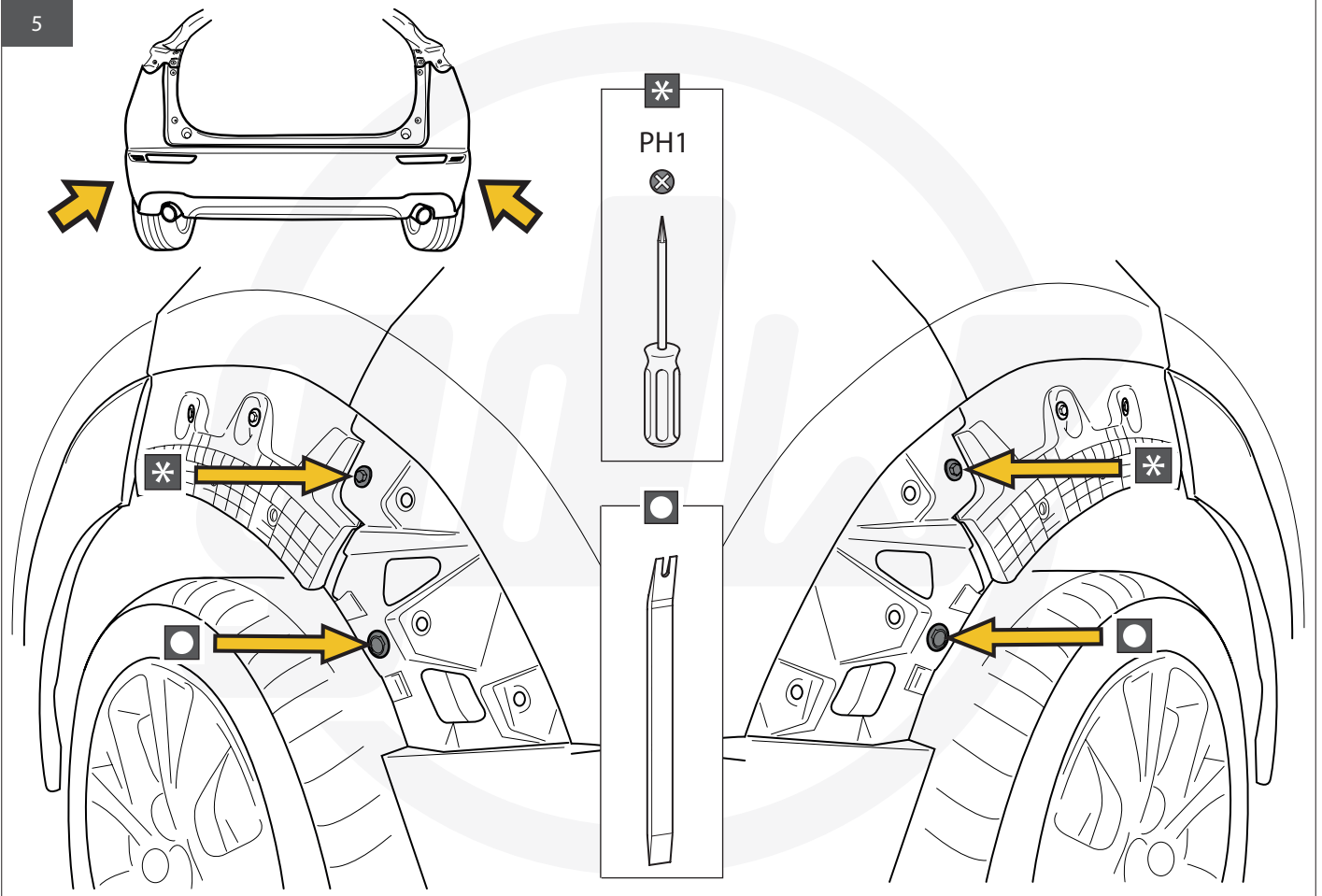

6

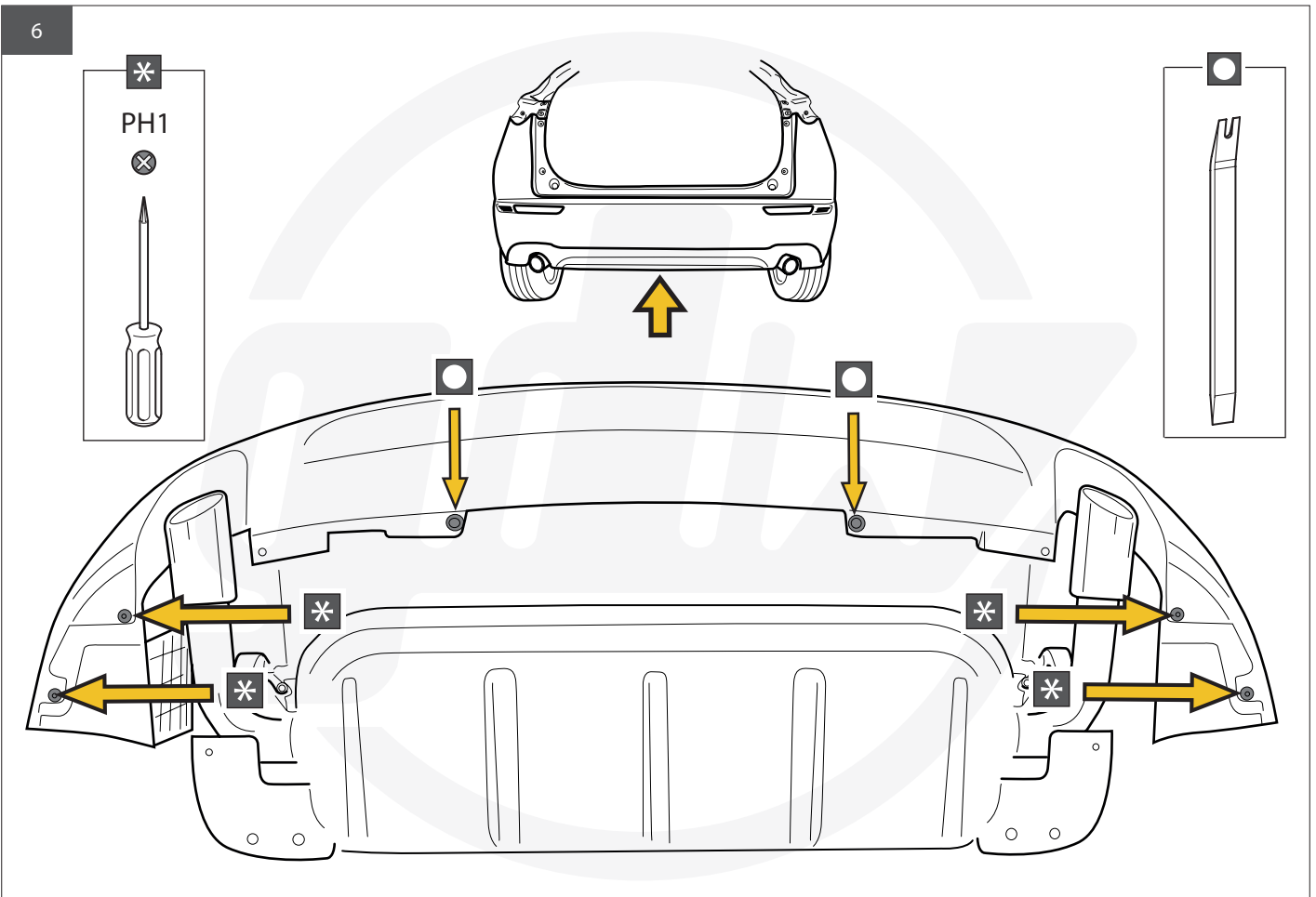

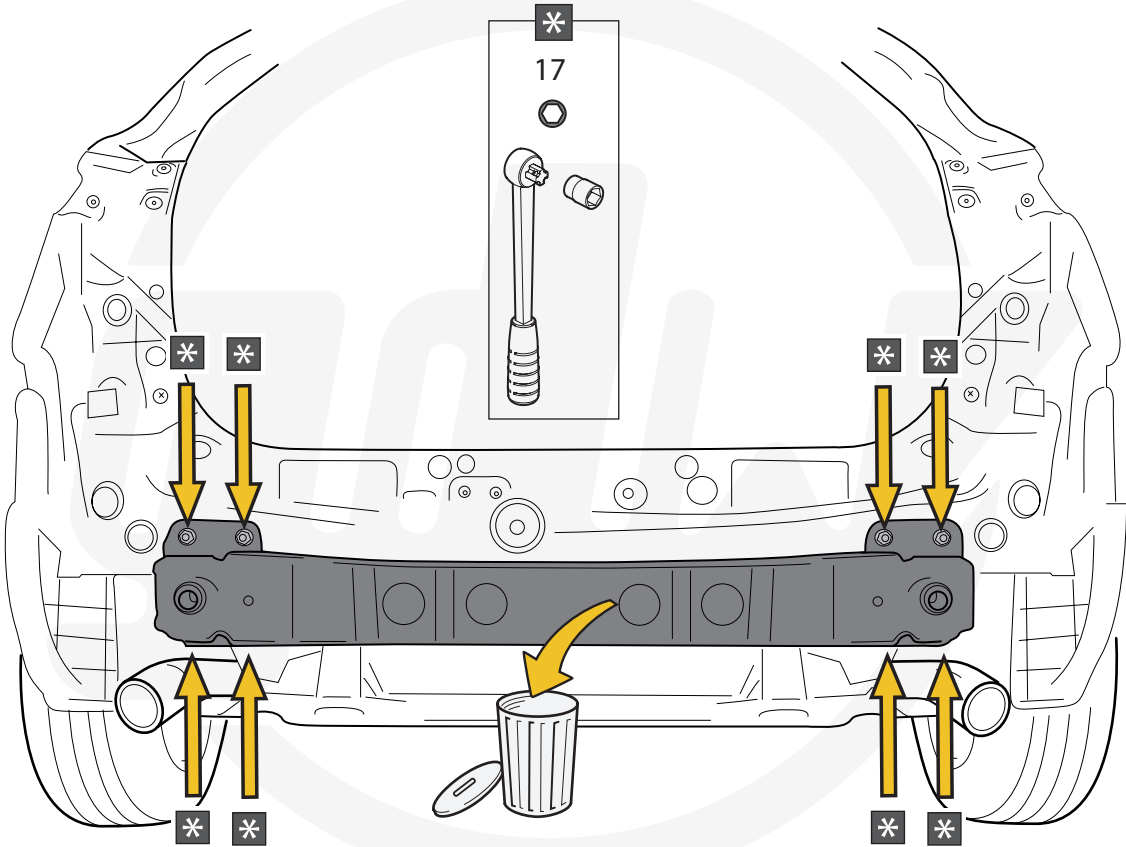
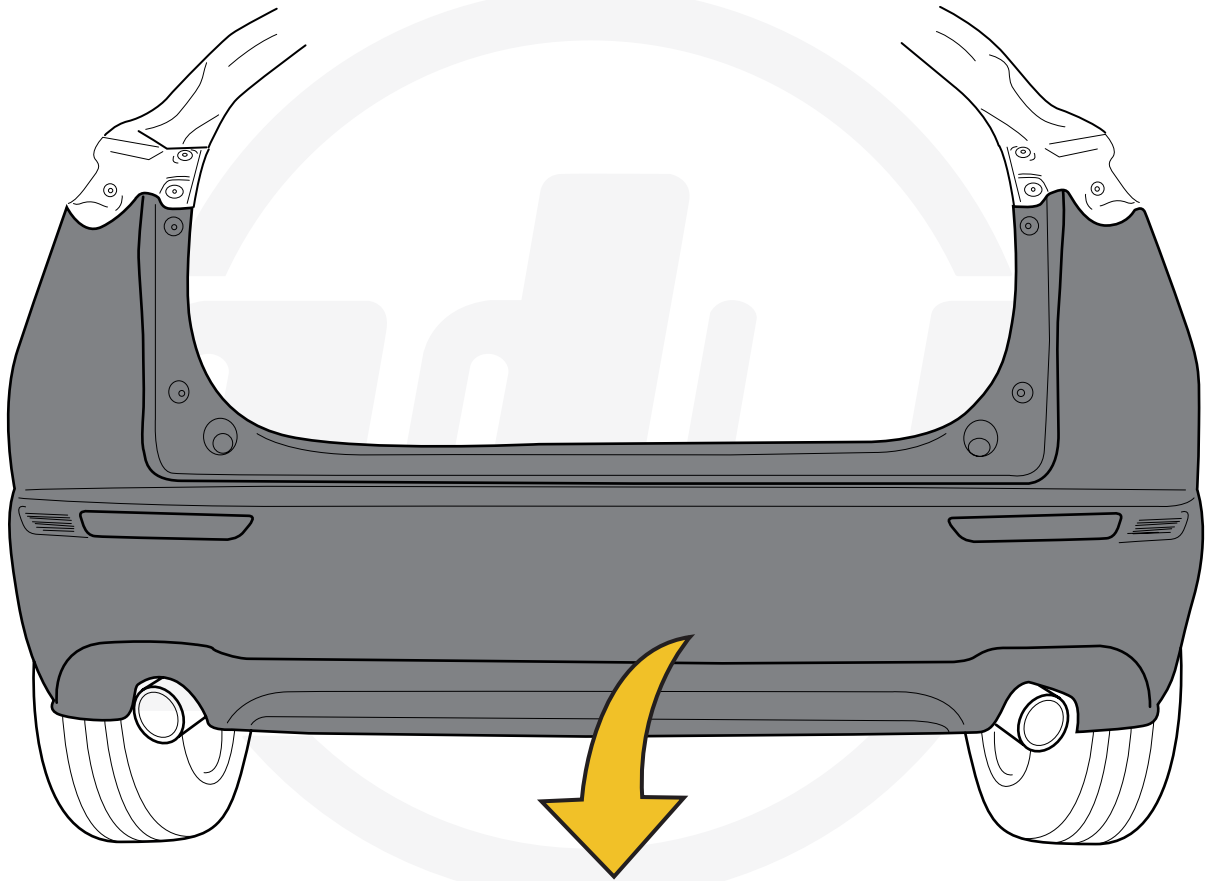

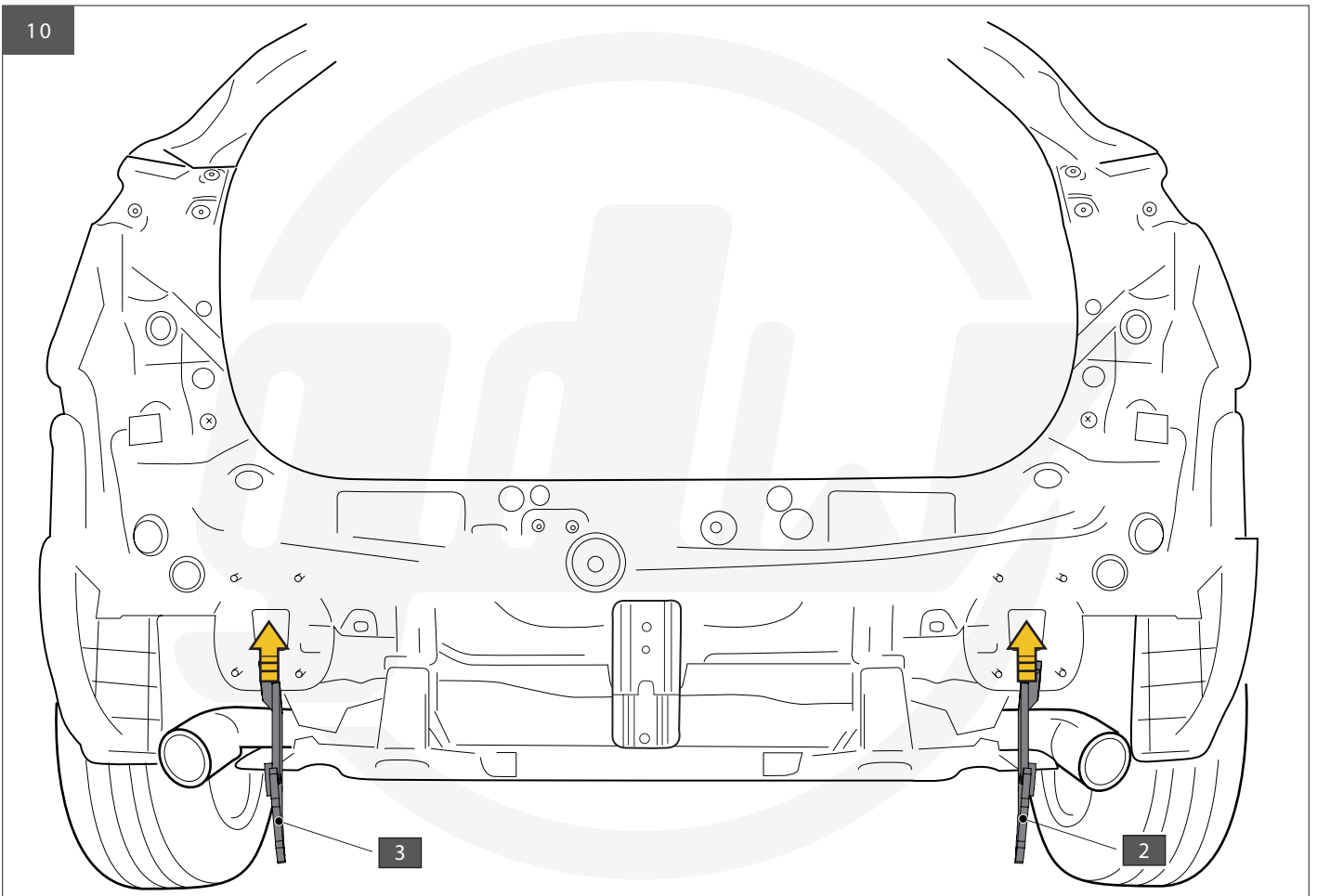
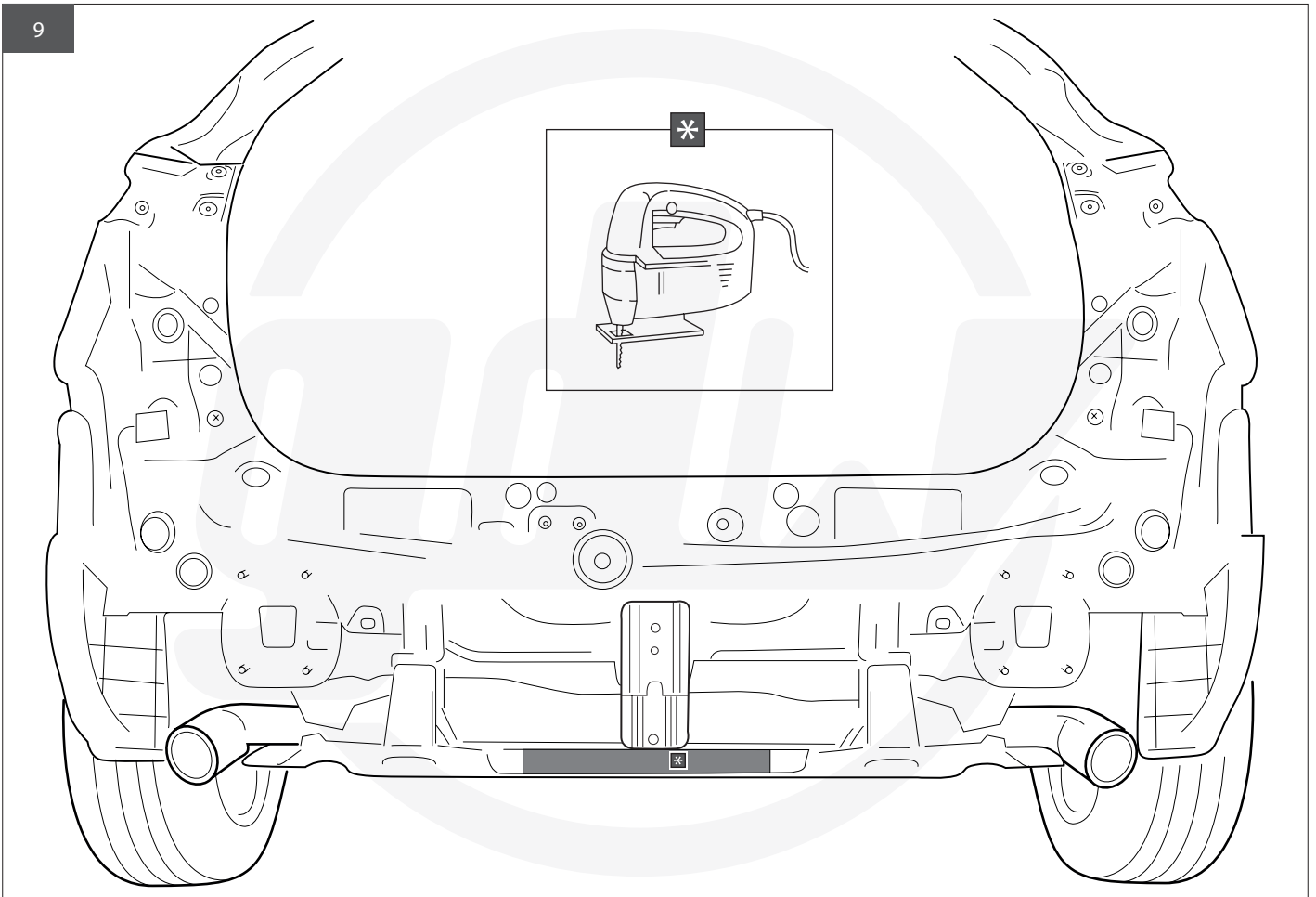

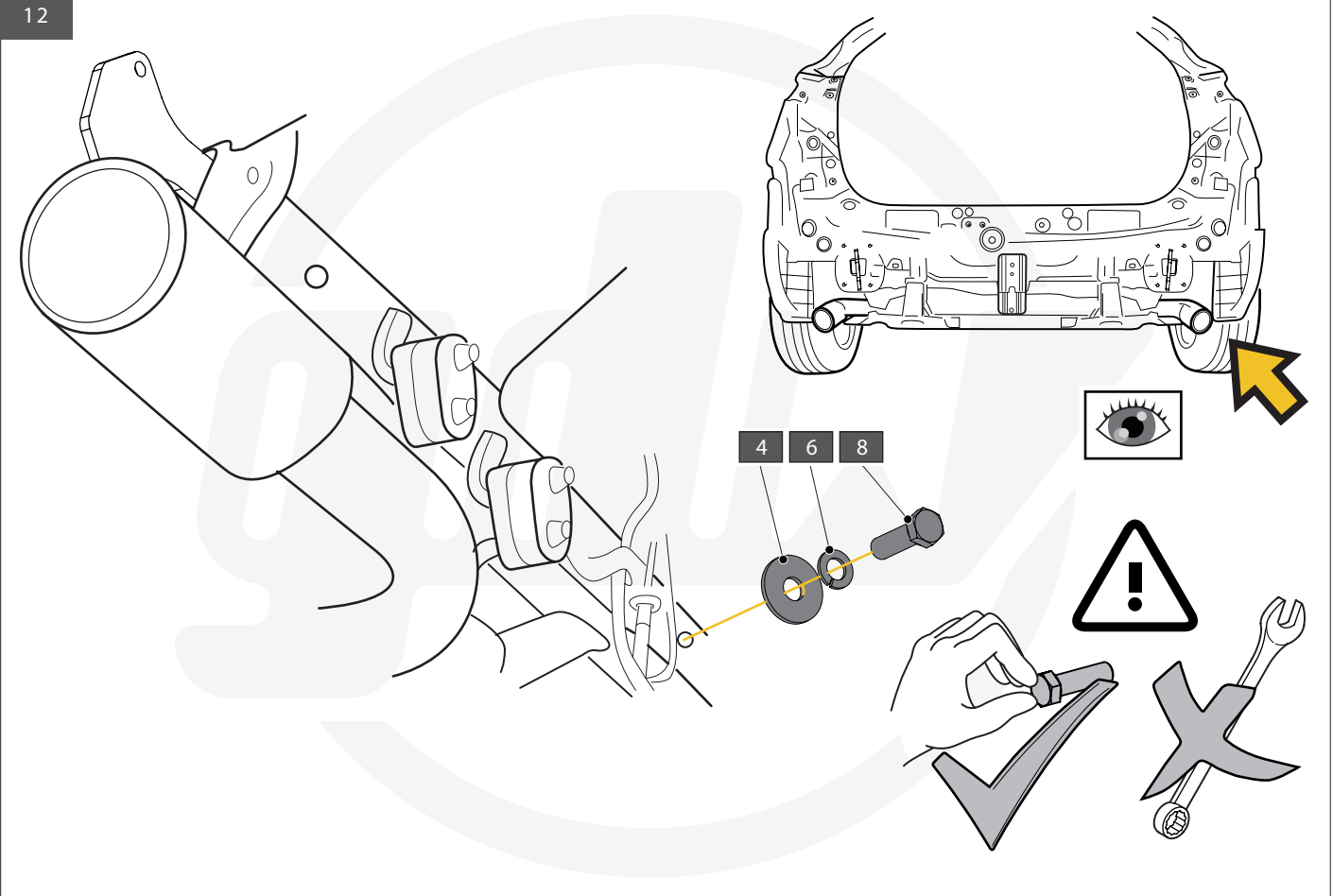
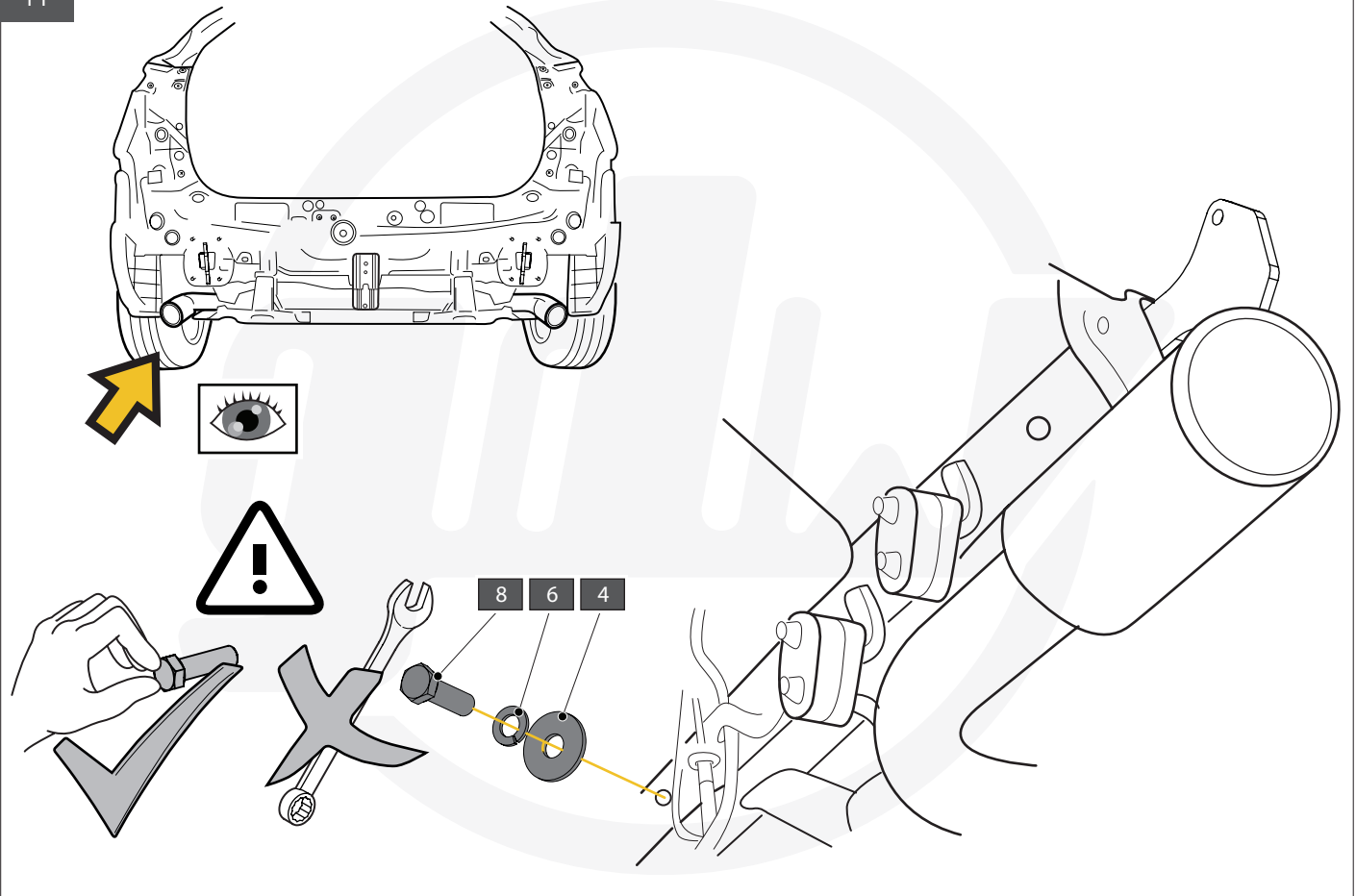

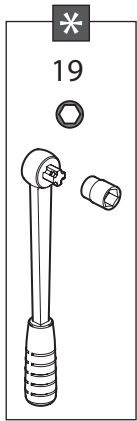
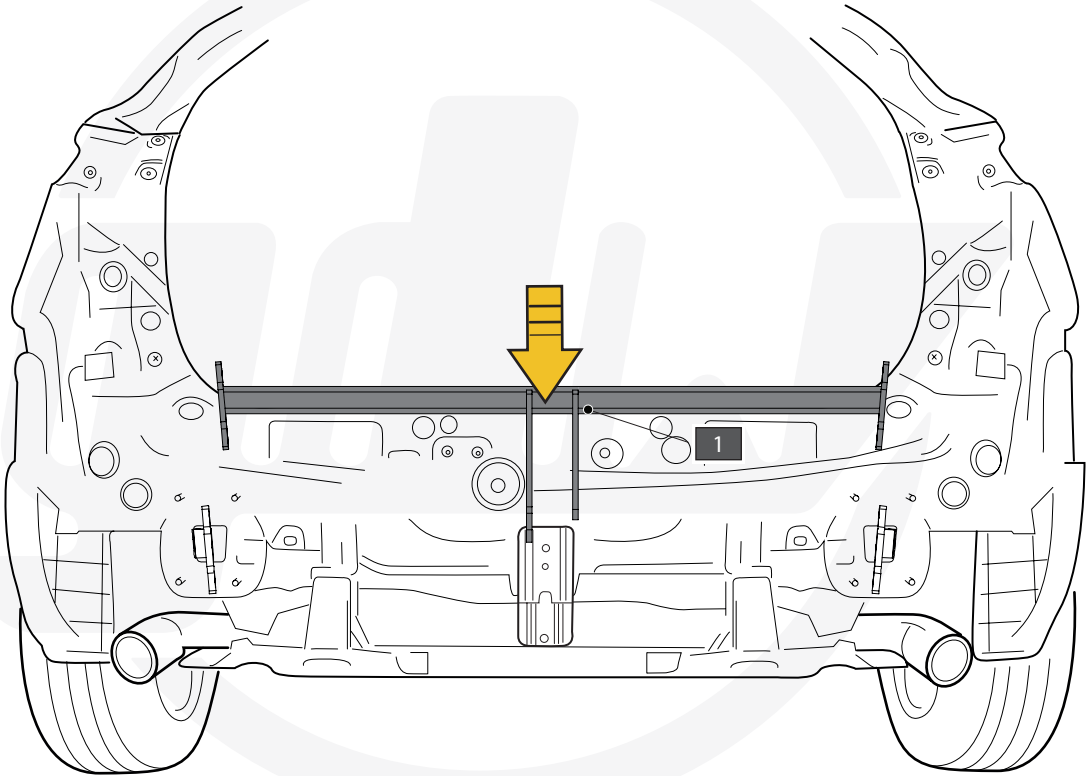

93,0 Nm

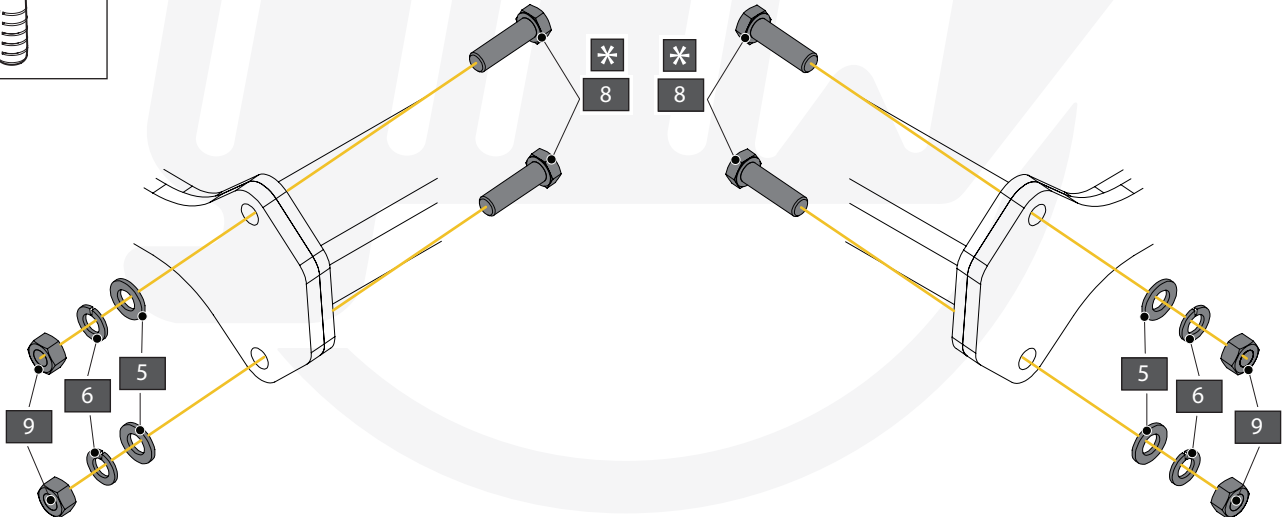
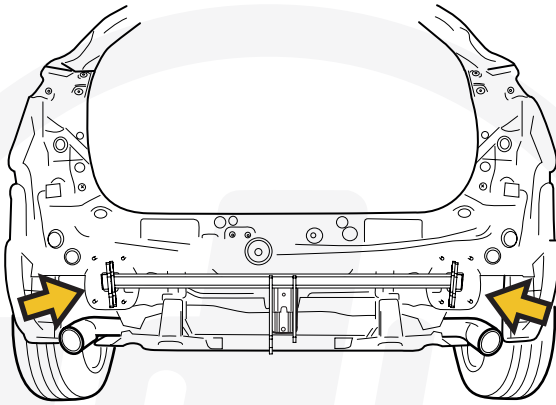

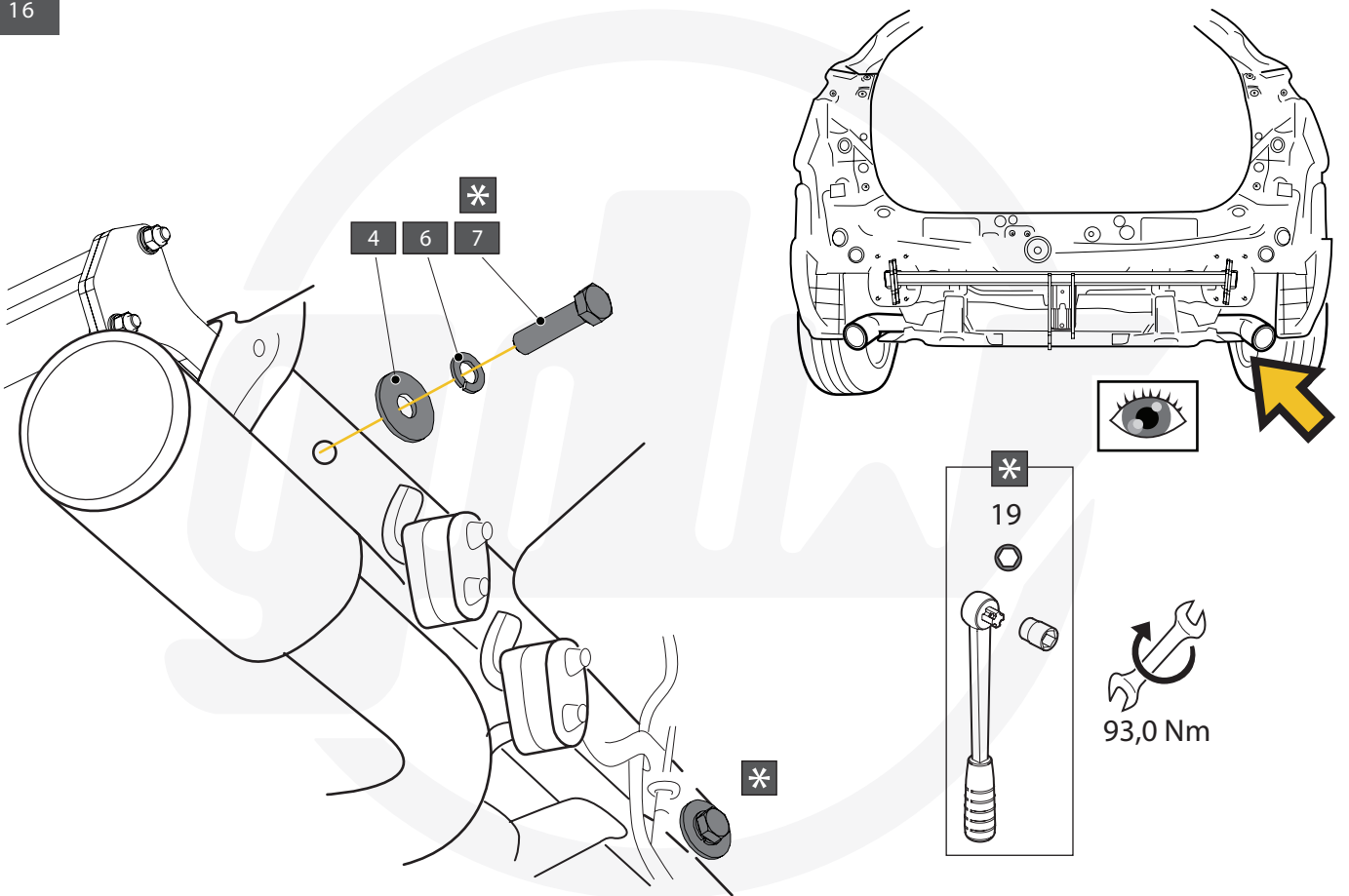
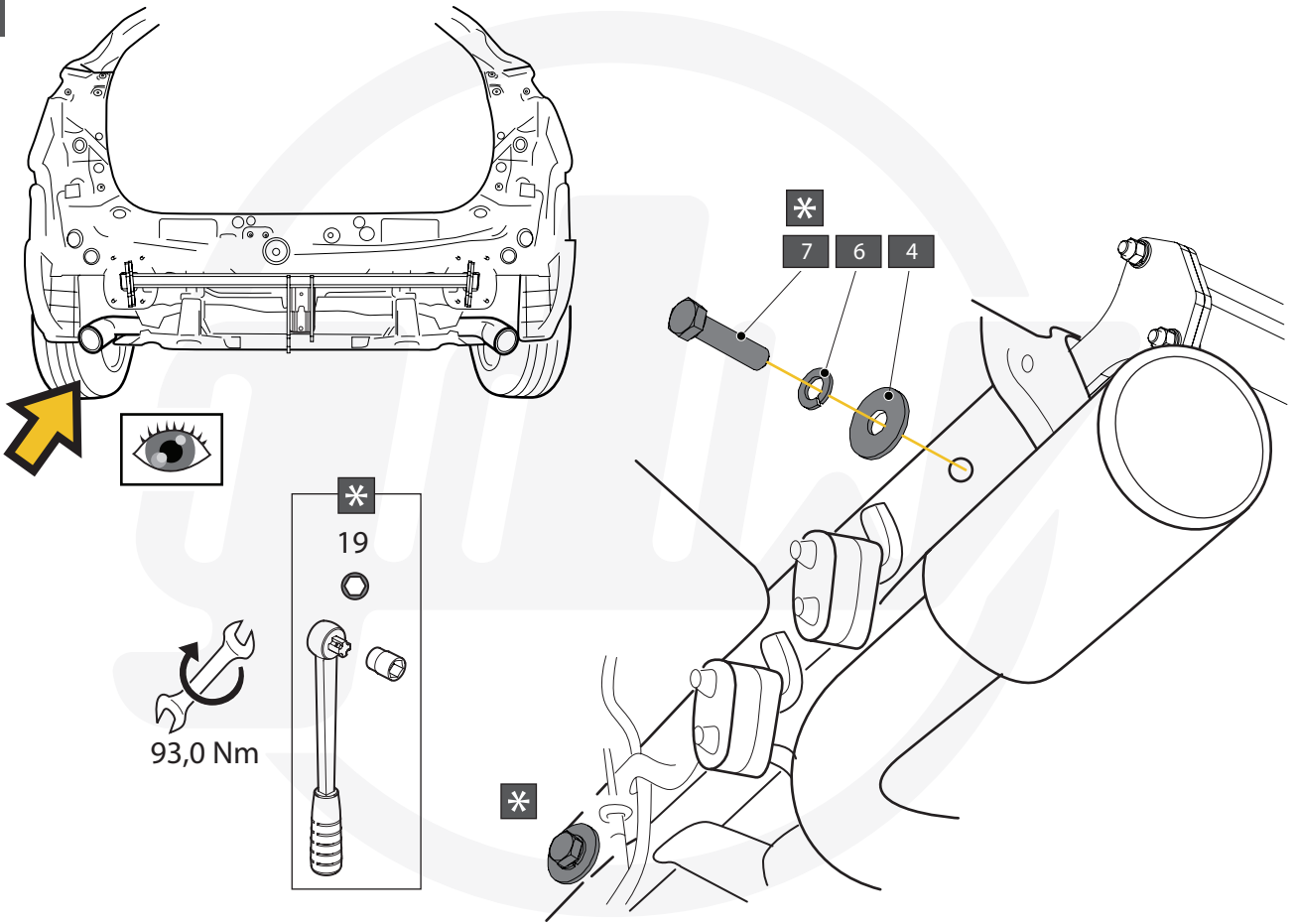

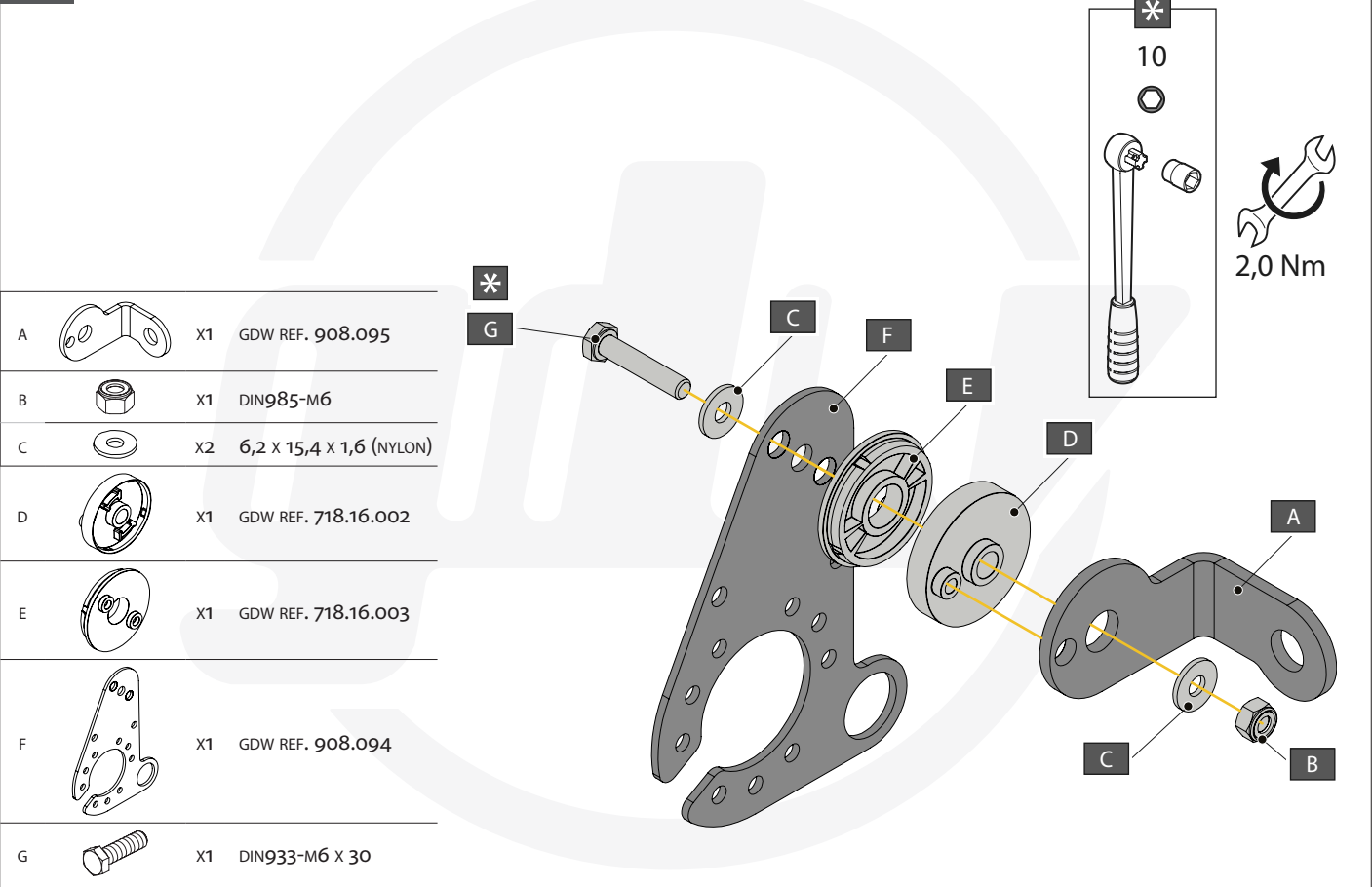
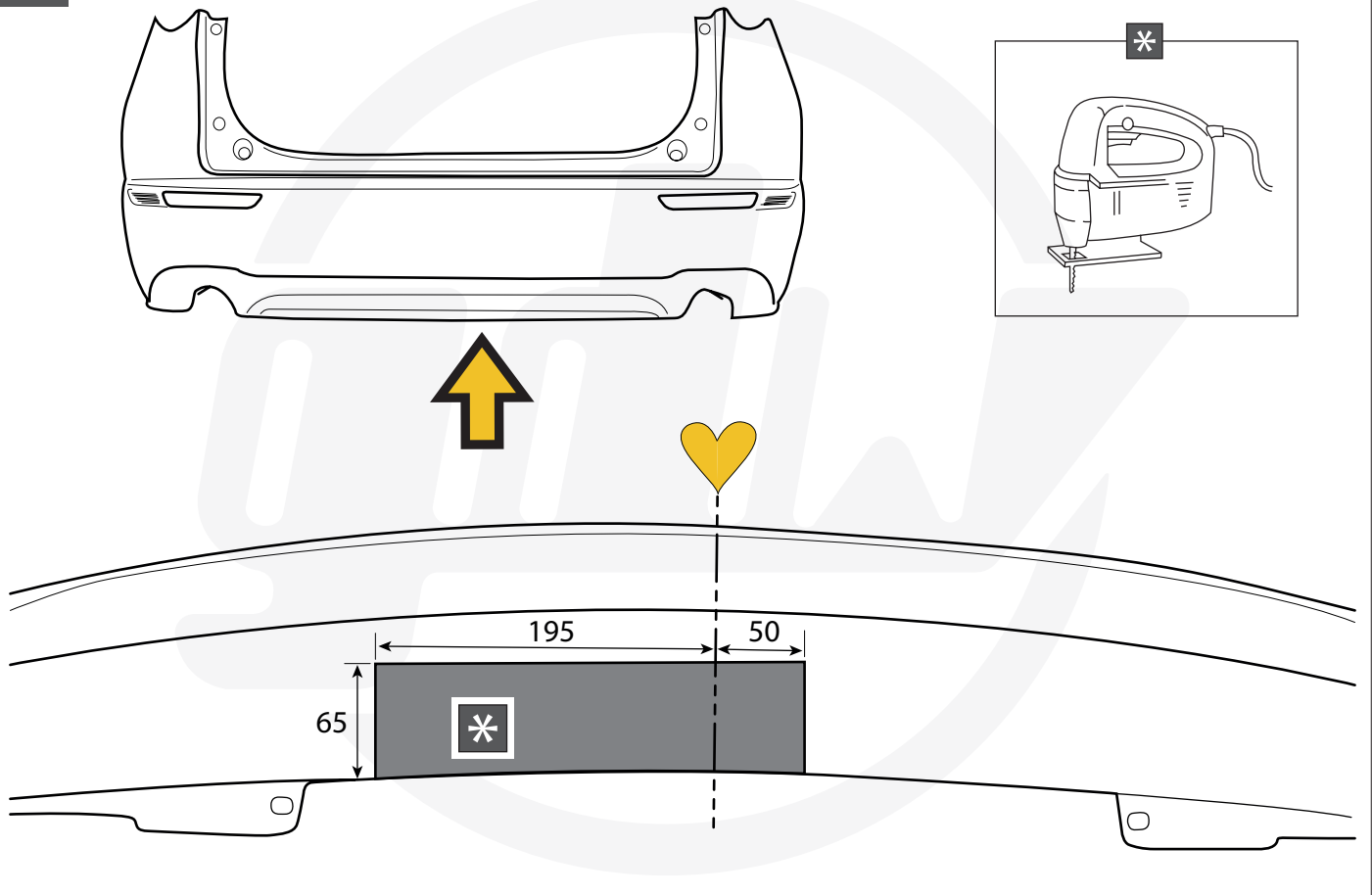

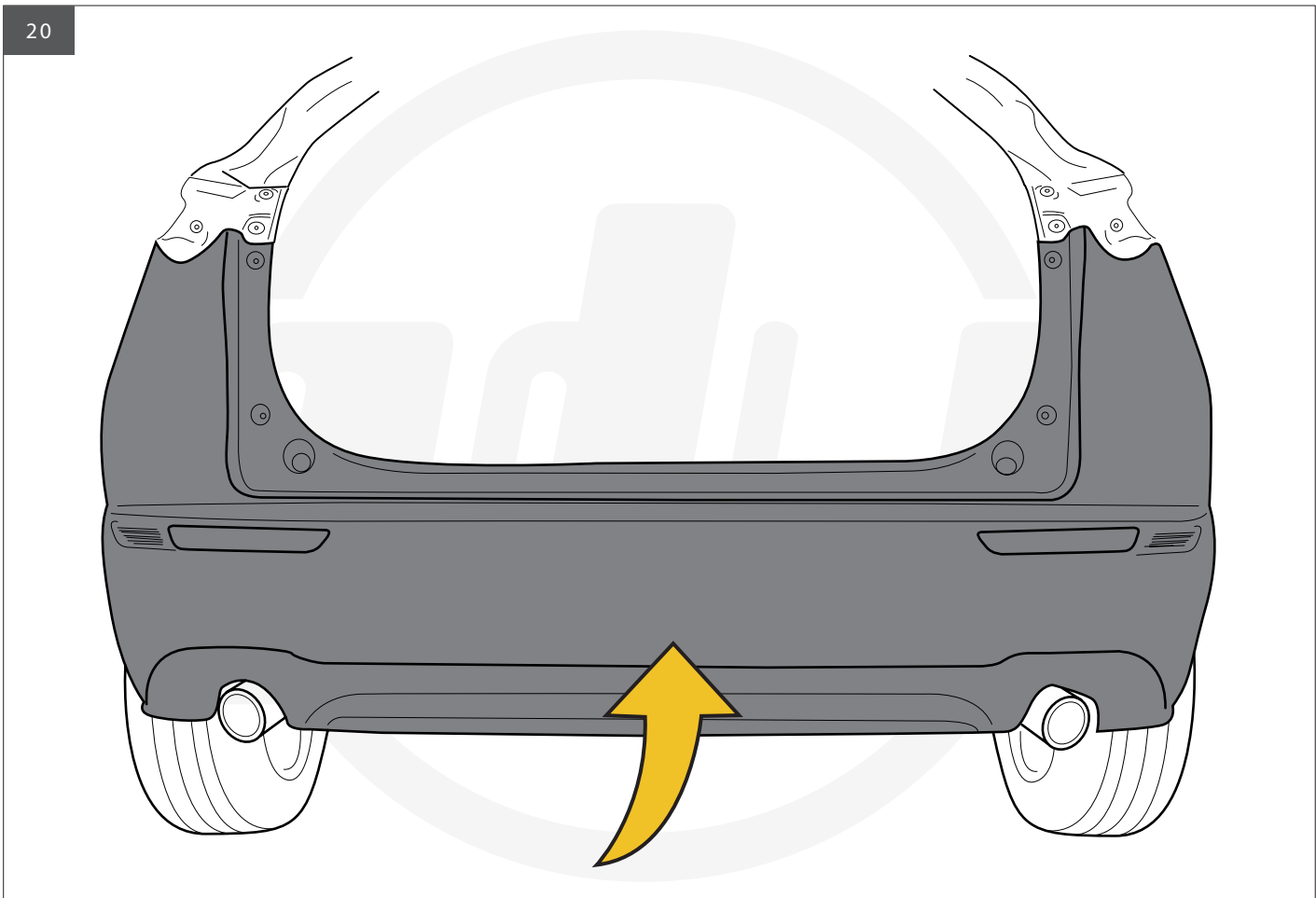
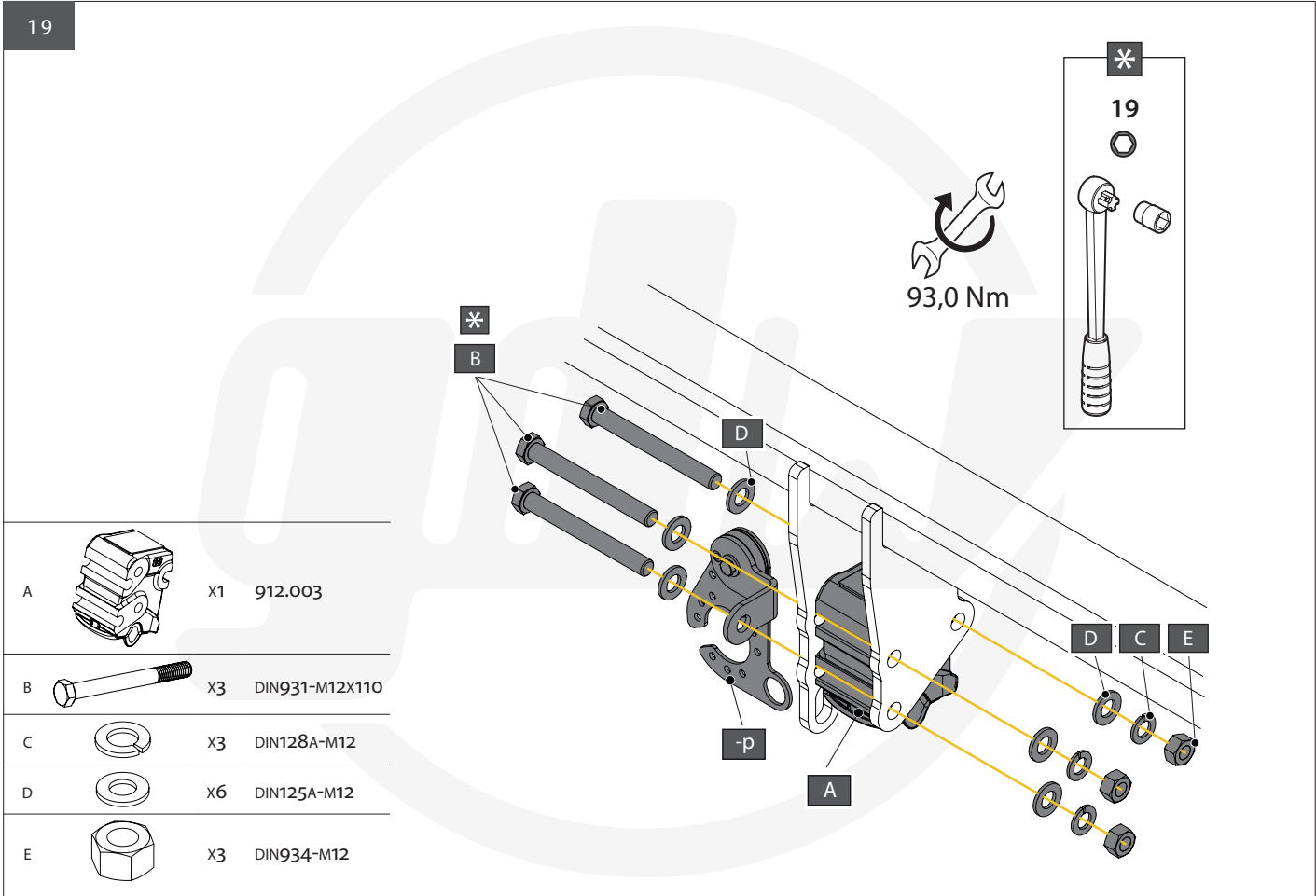

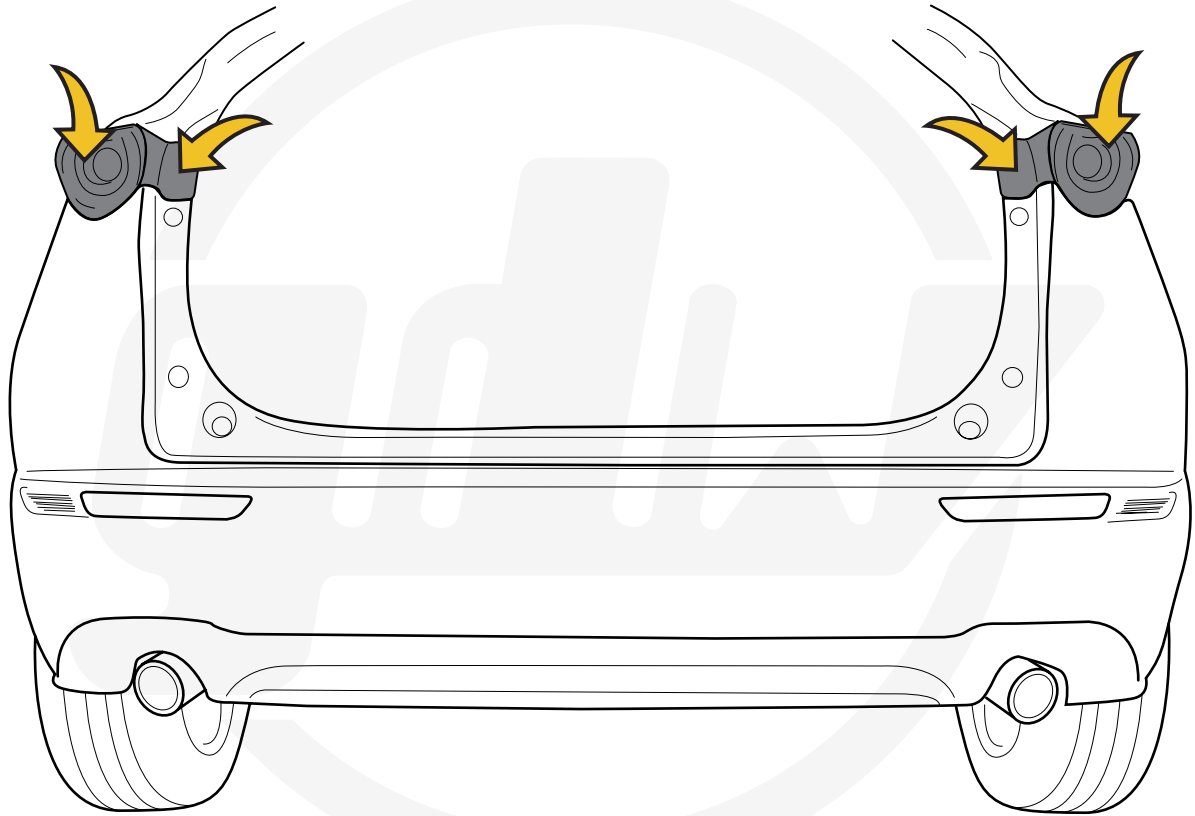

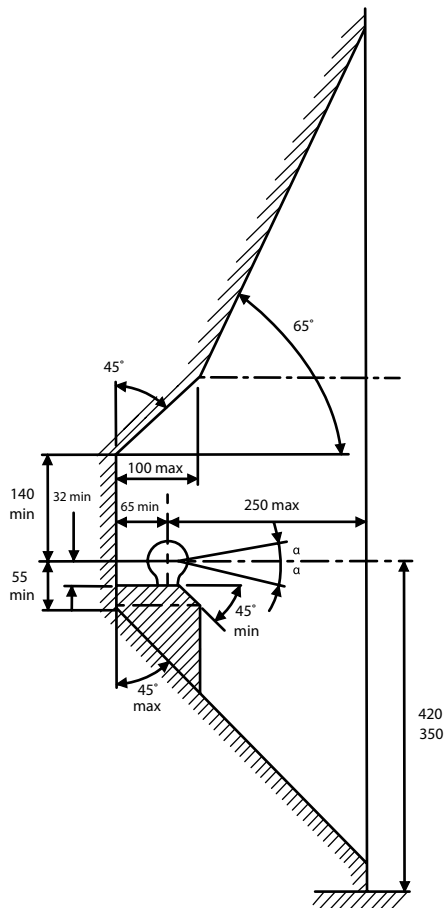

De tussenruimte conform bijlage VII, afbeelding 25 (a, b) van het reglement nr. 55 UN/ECE moet in acht genomen worden. Deze voorschriften zijn niet van toepassing op terreinvoertuigen klasse G.

La zone de dégagement doit être garantie conformément à l'annexe VII, illustration 25 (a, b) de la règle n° 55 UN/ECE. Ces dispositions ne s'appliquent pas aux véhicules tout-terrain classe G.

The clearance specified in appendix VII, diagram 25 (a, b) of regulation nr. 55 UN/ECE must be guaranteed. These requirements shall not apply to all-terrain vehicles class G.

Der Freiraum nach Anhang VII, Abbildung 25 (a, b) der Regulierung nr. 55 UN/ECE ist zu gewährleisten. Diese Vorschriften gelten nicht für Geländefahrzeugen Klasse G.

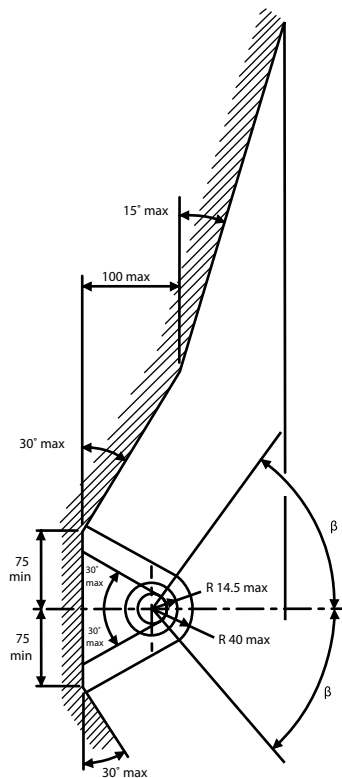

Bij toelaatbaar totaal gewicht van het voertuig

Pour poids total en charge autorisé du véhicule

At laden weight of the vehicle

Bei zulässigem Gesamtgewicht des Fahrzeuges

Peso total admisible del vehículo

Ved tilladt samlet vægt for køretøjet